

Rev:	Date	By	Chk	Description
A.1	4/22/13	PJE	AKH	ECO 0024

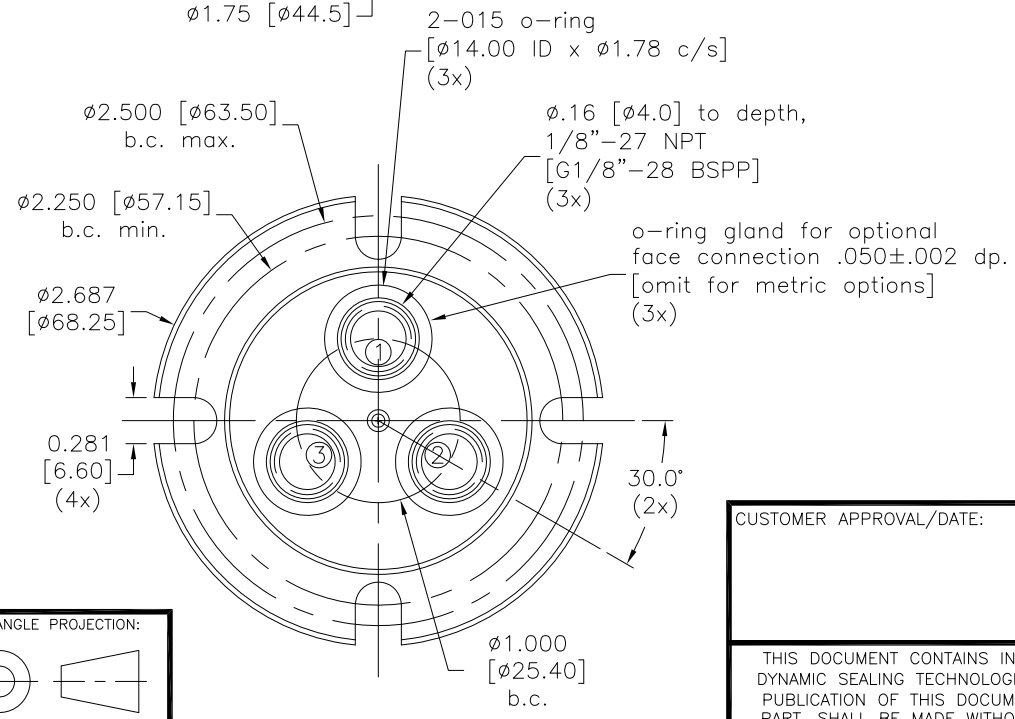
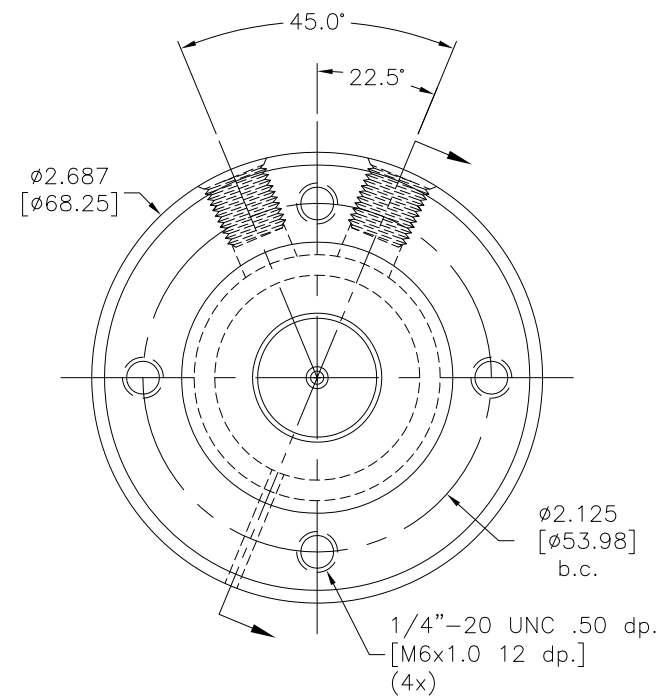
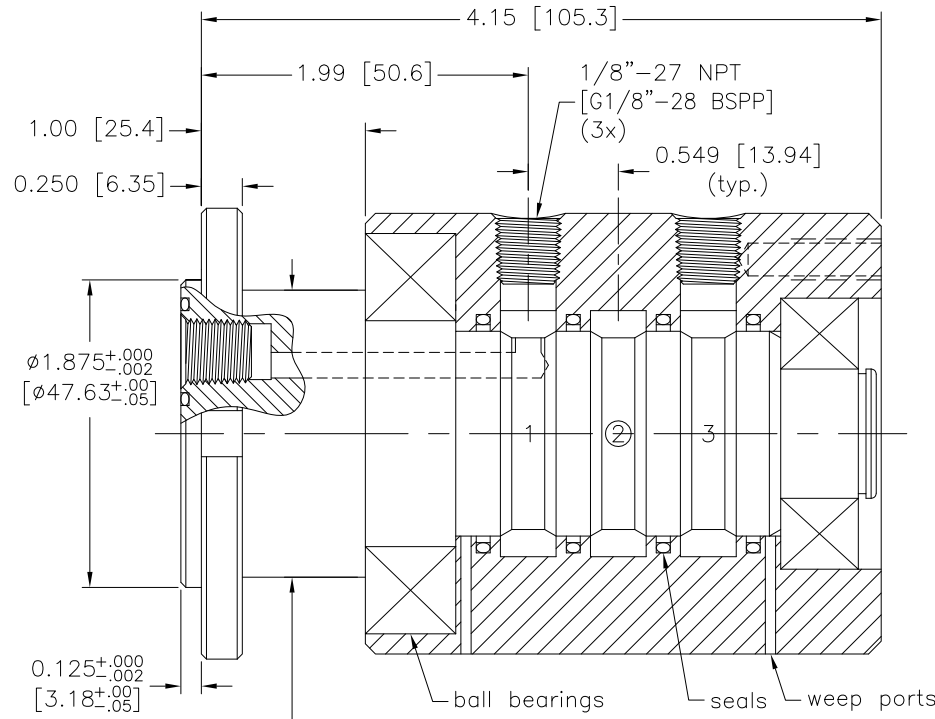

**Notes:**

1. Union will be rotated for seal break-in and static air tested.
2. Media must be filtered, clean and free of abrasive content or reduced union life will result.
3. Stainless steel union construction available by using GPS in place of GP in the series designation prefix.
4. Metric connections and threads available by using GPM in place of GP in the series designation prefix.
5. Stainless steel union construction and metric connections/threads available by using GPSM in place of GP in the series designation prefix.

Drawn	JSM	1/20/02
Checked	PJE	2/10/06
Checked	PJE	4/18/08

TOLERANCE EXCEPT AS NOTED	
X.X	±.125
X.XX	±.015
X.XXX	±.005
ANGLES	± 0.5°



CUSTOMER APPROVAL/DATE:

THIS DOCUMENT CONTAINS INFORMATION WHICH IS PROPRIETARY TO DYNAMIC SEALING TECHNOLOGIES, INC. (DSTI) NO REPRODUCTION OR PUBLICATION OF THIS DOCUMENT OR IT'S CONTENTS, IN WHOLE OR PART, SHALL BE MADE WITHOUT THE WRITTEN CONSENT FROM DSTI.

SHAFT MTL/PLTING:	
CARBON STL / 17-4 SSSL	60-62 Rc / 40-47 Rc
BLK OXIDE / TDC	
HOUSING MTL/PLTING:	
CARBON STL / 303 SSSL	BLK OXIDE /

CUSTOMER:	STOCK
P/N:	GP(S)(M)-130
REV:	A.1

