

Rev:	Date	By	Chk	Description
A.1	3/4/13	PJE	RAW	ECO 0024

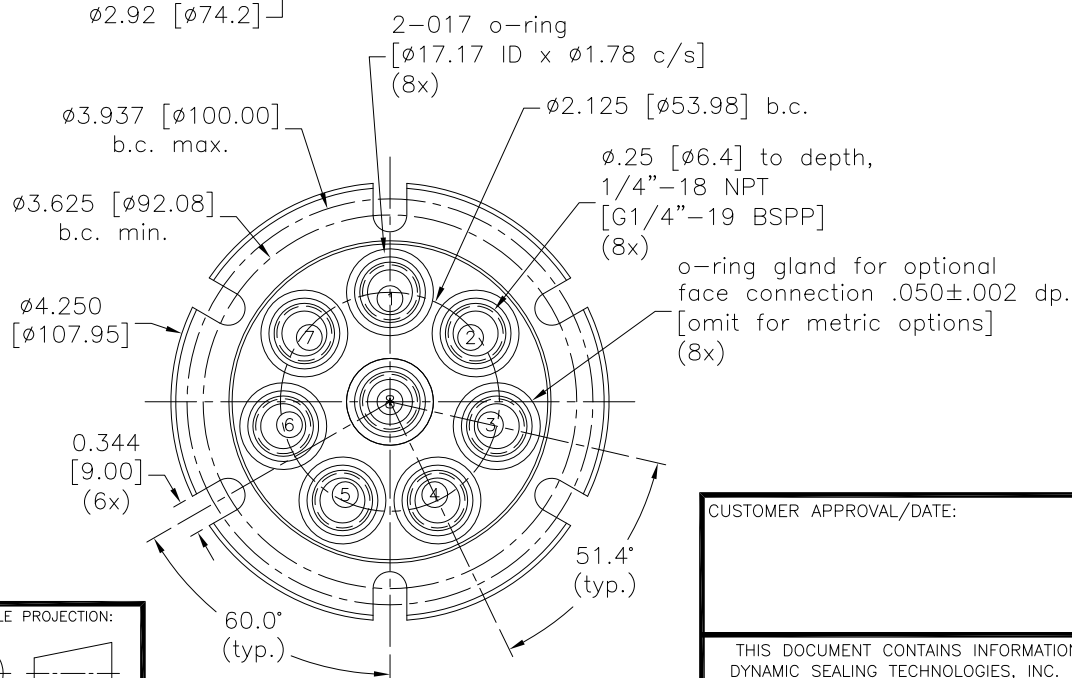

- Notes:**
1. Union will be rotated for seal break-in and static air tested.
 2. Media must be filtered, clean and free of abrasive content or reduced union life will result.
 3. Stainless steel union construction available by using GPS in place of GP in the series designation prefix.
 4. Metric connections and threads available by using GPM in place of GP in the series designation prefix.
 5. Stainless steel union construction and metric connections/threads available by using GPSM in place of GP in the series designation prefix.

Drawn	JSM	1/20/02	TOLERANCE
Checked	PJE	2/9/06	EXCEPT AS NOTED
Checked	PJE	4/18/08	X.X ±.125
			X.XX ±.015
			X.XXX ±.005
			ANGLES ± 0.5°

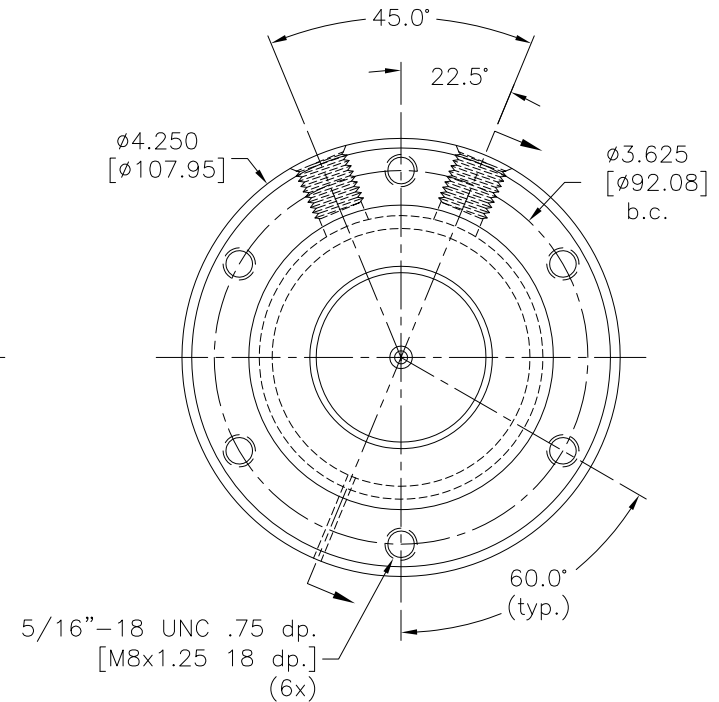
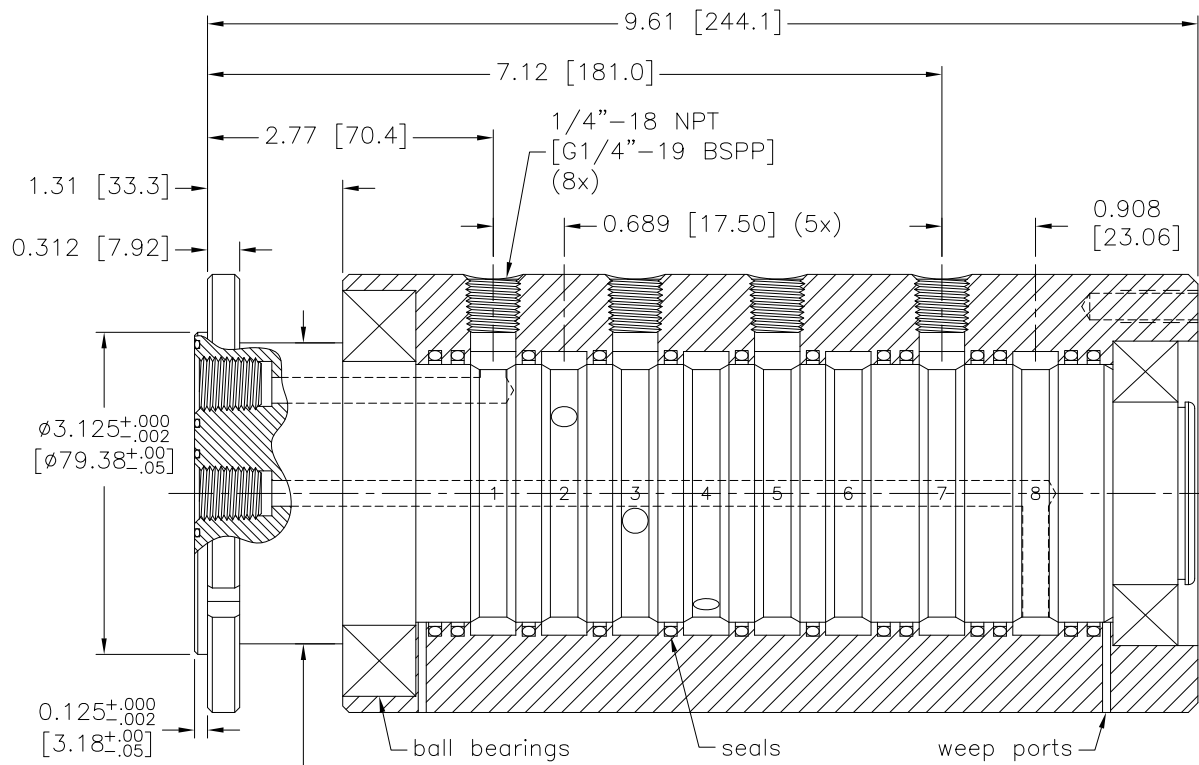

CUSTOMER APPROVAL/DATE:

SHAFT MTL/PLTING:
 CARBON STL / 17-4 SSSL
 60-62 Rc / 40-47 Rc
 BLK OXIDE / TDC

CUSTOMER: STOCK

THIS DOCUMENT CONTAINS INFORMATION WHICH IS PROPRIETARY TO DYNAMIC SEALING TECHNOLOGIES, INC. (DSTI) NO REPRODUCTION OR PUBLICATION OF THIS DOCUMENT OR IT'S CONTENTS, IN WHOLE OR PART, SHALL BE MADE WITHOUT THE WRITTEN CONSENT FROM DSTI.

HOUSING MTL/PLTING:
 CARBON STL / 303 SSSL
 BLK OXIDE /

P/N: GP(S)(M)-280
 REV: A.1

