

Rev:	Date	By	Chk	Description
A.1	9/10/12	PJE	RAW	ECO 0024

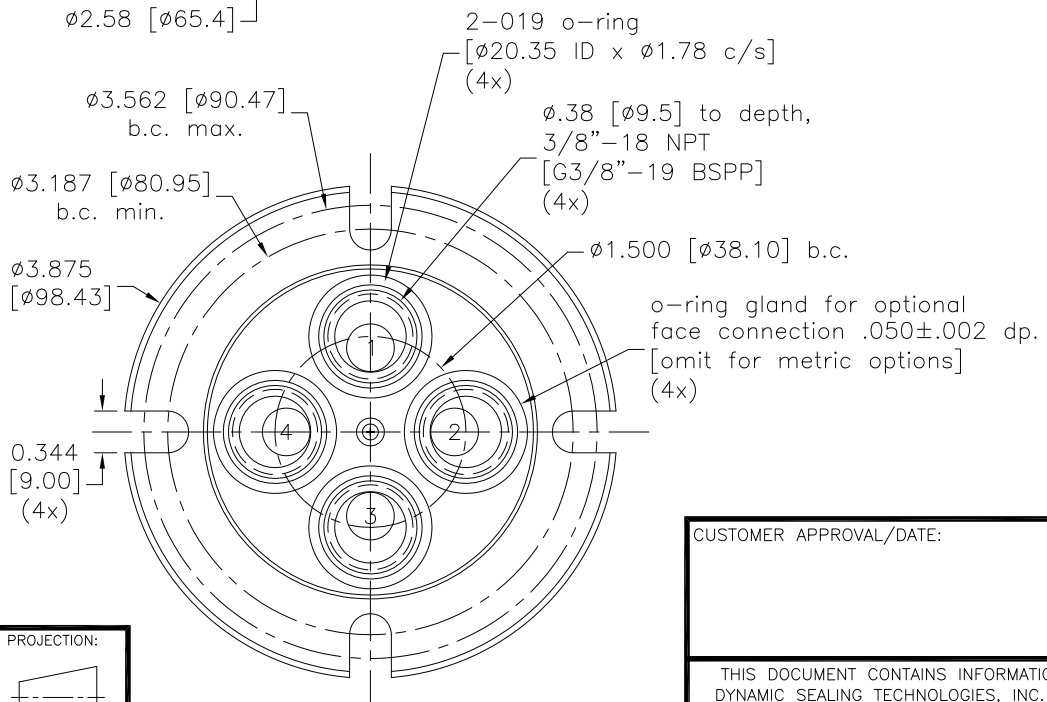

- Notes:**
1. Union will be rotated for seal break-in and static air tested.
 2. Media must be filtered, clean and free of abrasive content or reduced union life will result.
 3. Stainless steel union construction available by using GPS in place of GP in the series designation prefix.
 4. Metric connections and threads available by using GPM in place of GP in the series designation prefix.
 5. Stainless steel union construction and metric connections/threads available by using GPSM in place of GP in the series designation prefix.

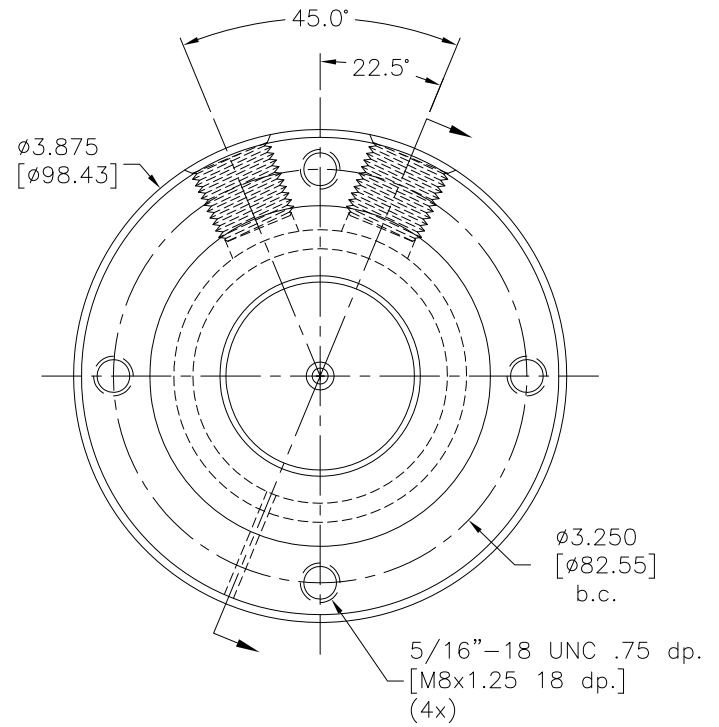
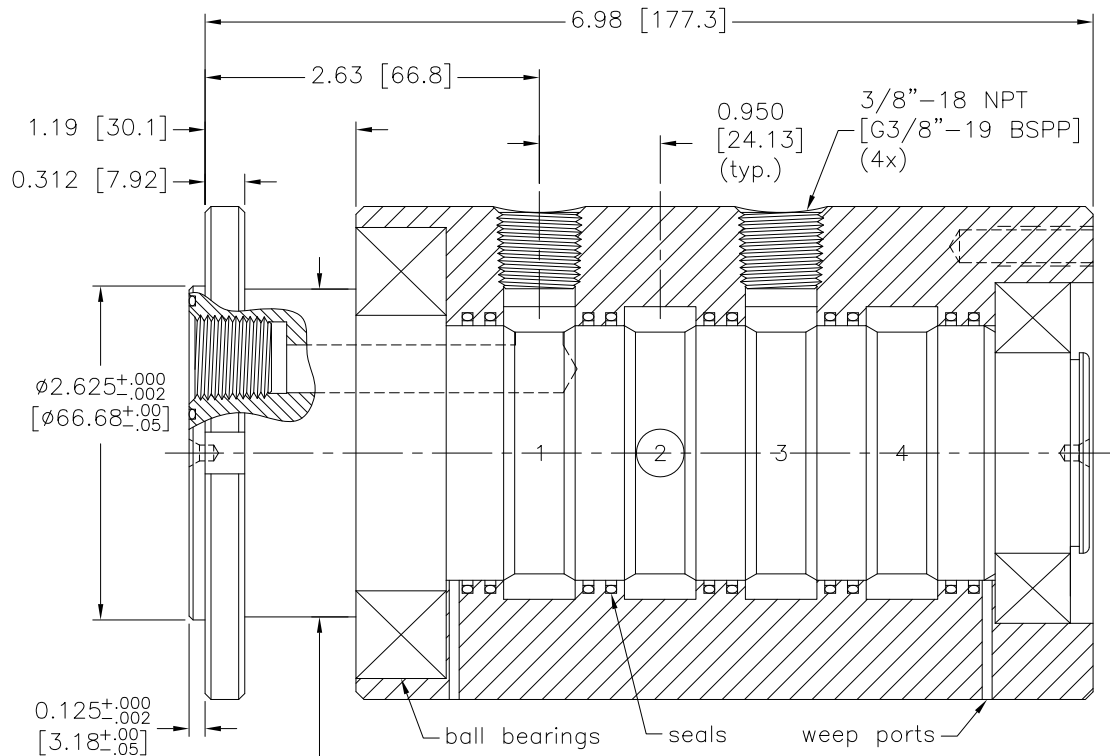
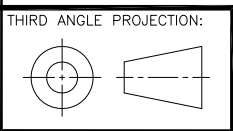

CUSTOMER APPROVAL/DATE:

THIS DOCUMENT CONTAINS INFORMATION WHICH IS PROPRIETARY TO DYNAMIC SEALING TECHNOLOGIES, INC. (DSTI) NO REPRODUCTION OR PUBLICATION OF THIS DOCUMENT OR IT'S CONTENTS, IN WHOLE OR PART, SHALL BE MADE WITHOUT THE WRITTEN CONSENT FROM DSTI.

Drawn	JSM	1/20/02
Checked	PJE	2/10/06
Checked	PJE	4/18/08

TOLERANCE EXCEPT AS NOTED	
X.X	±.125
X.XX	±.015
X.XXX	±.005
ANGLES	± 0.5°

SHAFT MTL/PLTING:	CARBON STL / 17-4 SSTL
	60-62 Rc / 40-47 Rc
	BLK OXIDE / TDC

HOUSING MTL/PLTING:	CARBON STL / 303 SSTL
	BLK OXIDE /

CUSTOMER: STOCK

P/N: GP(S)(M)-340 REV: A.1